

**THIS TECHNICAL DOCUMENT BROUGHT
TO YOU AT NO COST FROM:**

ARCADEDOCS.COM

**THE INTERNET'S LARGEST REFERENCE LIBRARY
SUPPORTING THE COIN-OPERATED
COLLECTOR AND OPERATOR COMMUNITIES**

Dedicated With Special Thanks To:

The Many Amusement Machine Manufacturers,
Collectors, Dealers, Designers, Distributors,
Engineers, Operators, and Players
That Have Generously Continued To Support Us
Throughout The Years

**MANUALS — SCHEMATICS — TECHNICAL BULLETINS
DIP SWITCH SETTINGS — PIN-OUTS — TRAINING**

Williams[®]

16-3007-103
November, 1982

Moon Patrol

DRAWING SET

FOR SERVICE...
NOTE NEW TOLL-FREE
TELEPHONE NUMBERS:

800-621-1253
IN ILLINOIS CALL:
800-572-1324



Williams[®]
ELECTRONICS, INC.

3401 N. California Ave., Chicago, IL 60618

CONTENTS

Interboard Wiring Diagram	1
Connector Identification and Block Diagram	2
D-9454 CPU Board (M-52-A-C) Sheet 1 of 2	3
D-9454 CPU Board (M-52-A-C) Sheet 2 of 2	4
D-9455 Character Board (M-52-B-C) Sheet 1 of 2	5
D-9455 Character Board (M-52-B-C) Sheet 2 of 2	6
D-9456 Scrolling Video Board (M-52-E-C) Sheet 1 of 2	7
D-9456 Scrolling Video Board (M-52-E-C) Sheet 2 of 2	8
C-9457 Sound Board (M-52-SOUND-C)	9
D-8784-3007 Power Supply Board Assembly Drawing	10
D-8784-3007 Power Supply Board Schematic Diagram	11
Power Wiring Diagram	12
Cabinet Wiring Diagram	13

- M52-A-C CPU BOARD
- M52-B-C CHARACTER BOARD
- M52-E-C SCROLLING VIDEO BOARD

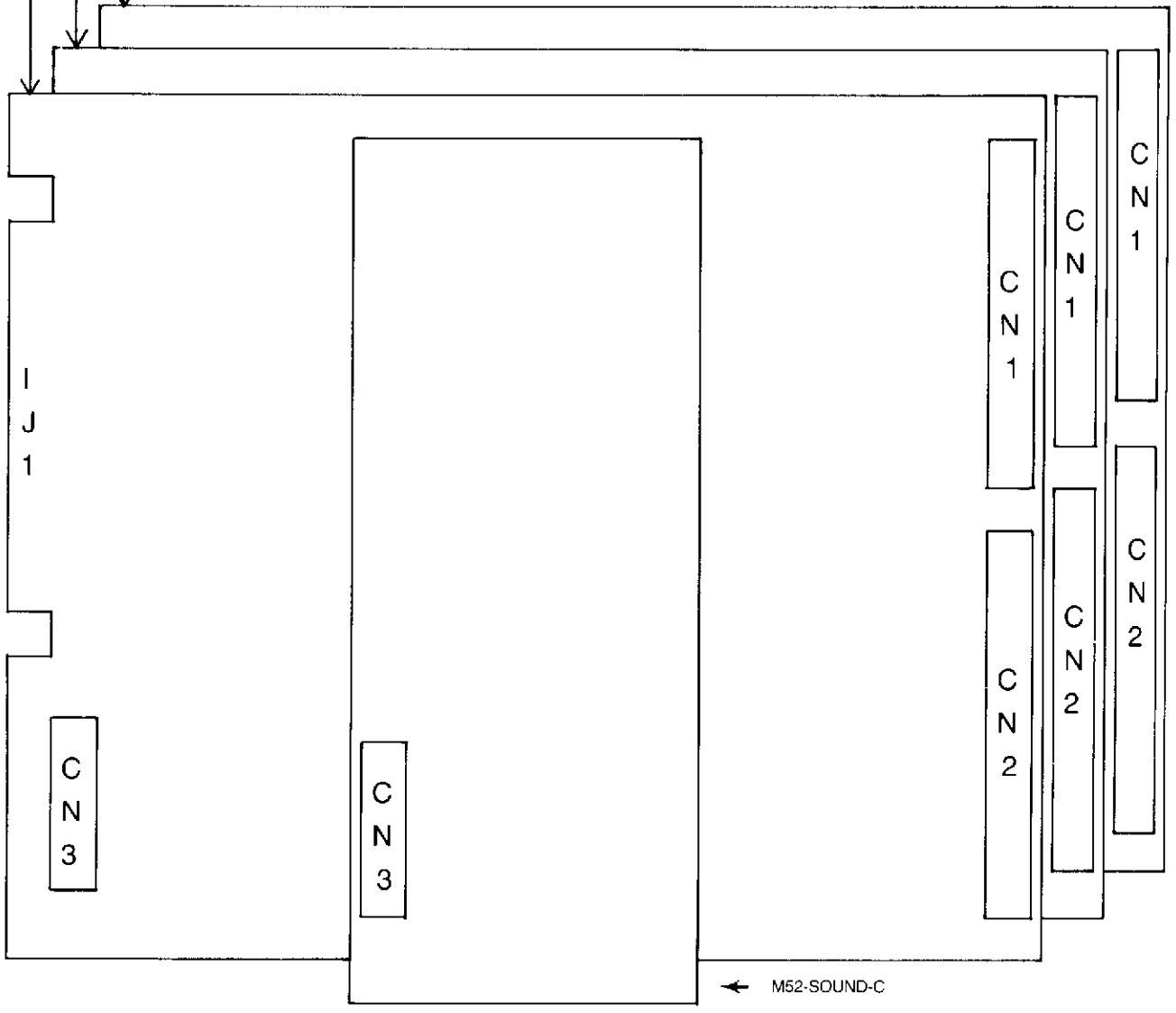

← M52-SOUND-C

DIP SWITCH NO. 1

ADJUSTMENT	OPTIONS	1
		ON
*RECOMMENDED SETTINGS		ON
+COIN MODE 1	2 PLAYS/1 COIN 3 PLAYS/1 COIN 4 PLAYS/1 COIN	
	5 PLAYS/1 COIN 6 PLAYS/1 COIN *1 PLAY/1 COIN	
	1 PLAY/2 COINS 1 PLAY/3 COINS 1 PLAY/4 COINS	
	1 PLAY/5 COINS 1 PLAY/6 COINS FREE PLAY	
+COIN MODE 2	1 PLAY/1 COIN 1 PLAY/2 COINS 1 PLAY/3 COINS	
	FREE PLAY 2 PLAYS/1 COIN 3 PLAYS/1 COIN 5 PLAYS/1 COIN 6 PLAYS/1 COIN	
# PATROL CARS	5 PATROL CARS *4 PATROL CARS 3 PATROL CARS 2 PATROL CARS	OFF ON OFF ON
ADDITIONAL CAR AT:	*10,000/30,000/50,000 20,000/40,000/60,000 10,000 ONLY NO EXTENDED PLAY	

DIP SWITCH NO. 2

ADJUSTMENT	OPTIONS	1
		OFF
*RECOMMENDED SETTINGS		OFF
FLIP PICTURE	NO YES	OFF ON
**CABINET TYPE	TABLE UPRIGHT	
COIN MODE SETTINGS FOR DIP SWITCH 1	COIN MODE 1 COIN MODE 2	
FREEZE SCREEN	*NO YES	
SECTOR-SELECTION FEATURE	*NO YES	
DEMO MODE	*NO YES	
TEST MODE	*NO YES	
SWITCH 4 (not used)		

*recommended settings
 **For upright games, select ON for switch 2. Table games require OFF.
 †For games with a single coin selector or 2 selectors of the same value, select ON.

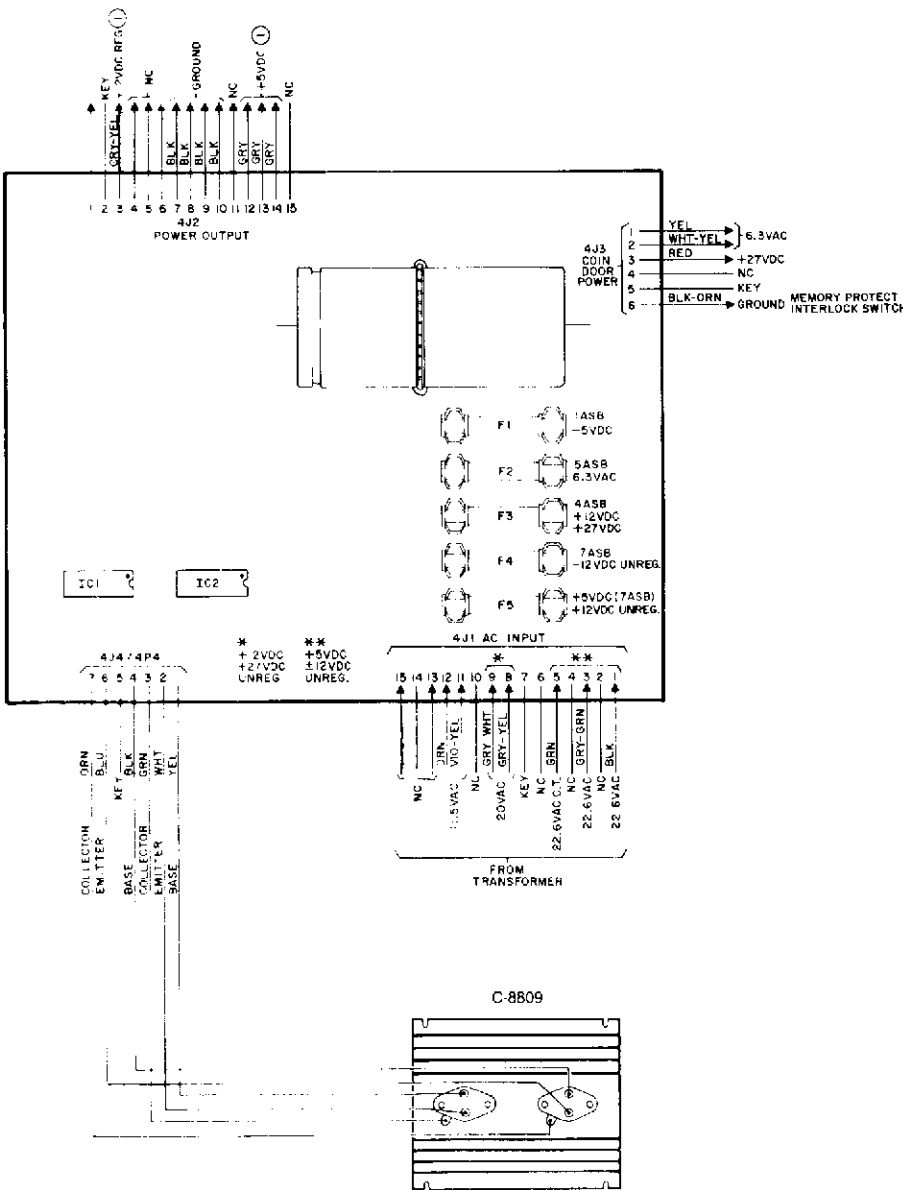
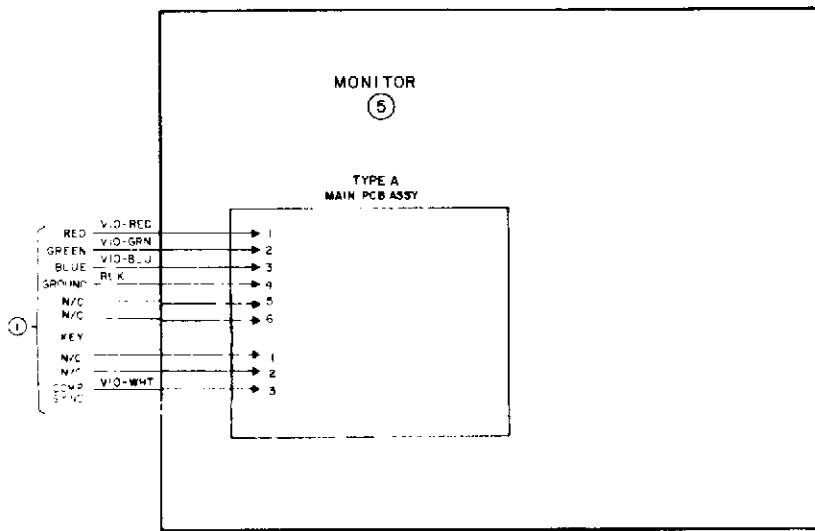

C-8809 heat sink assembly

Part No.	Description
5162-09425	2N6057, Transistor, NPN
5161-09552	2N3055, Transistor, NPN
5705-09684	Heat Sink
5700-09445	Socket, TO3
5701-09562	Thermal Pad
4006-01003-10	Machine Screw 6-32x5/8"

DIP SWITCH SETTINGS

DIP SWITCH NO. 1

ADJUSTMENT	OPTIONS	SWITCH NUMBER							
		1	2	3	4	5	6	7	8
*RECOMMENDED SETTINGS		ON	OFF	OFF	OFF	OFF	OFF	OFF	OFF
†COIN MODE 1	2 PLAYS/1 COIN					OFF	OFF	OFF	ON
	3 PLAYS/1 COIN					ON	OFF	OFF	ON
	4 PLAYS/1 COIN					OFF	ON	OFF	ON
	5 PLAYS/1 COIN					ON	ON	OFF	ON
†COIN MODE 2	6 PLAYS/1 COIN					OFF	OFF	ON	ON
	*1 PLAY/1 COIN					OFF	OFF	OFF	OFF
	1 PLAY/2 COINS					ON	OFF	OFF	OFF
	1 PLAY/3 COINS					OFF	ON	OFF	OFF
# PATROL CARS	1 PLAY/4 COINS					ON	ON	OFF	OFF
	1 PLAY/5 COINS					OFF	OFF	ON	OFF
	1 PLAY/6 COINS					ON	OFF	ON	OFF
	FREE PLAY					ON	ON	ON	ON
*COIN MODE 2	1 PLAY/1 COIN					OFF	OFF		
	1 PLAY/2 COINS					ON	OFF		
	1 PLAY/3 COINS					OFF	ON		
# PATROL CARS	FREE PLAY					ON	ON		
	2 PLAYS/1 COIN							OFF	OFF
	3 PLAYS/1 COIN							ON	ON
*COIN MODE 2	5 PLAYS/1 COIN							OFF	OFF
	6 PLAYS/1 COIN							ON	ON
	5 PATROL CARS	OFF	OFF						
	*4 PATROL CARS	ON	OFF						
ADDITIONAL CAR AT:	3 PATROL CARS	OFF	ON						
	2 PATROL CARS	ON	ON						
	*10,000/30,000/50,000			OFF	OFF				
	20,000/40,000/60,000			ON	OFF				
ADDITIONAL CAR AT:	10,000 ONLY			OFF	ON				
	NO EXTENDED PLAY			ON	ON				

DIP SWITCH NO. 2

ADJUSTMENT	OPTIONS	SWITCH NUMBER							
		1	2	3	4	5	6	7	8
*RECOMMENDED SETTINGS		OFF	ON	†	OFF	OFF	OFF	OFF	OFF
FLIP PICTURE	NO YES	OFF ON							
**CABINET TYPE	TABLE UPRIGHT		OFF ON						
COIN MODE SETTINGS FOR DIP SWITCH 1	COIN MODE 1 COIN MODE 2			OFF ON					
FREEZE SCREEN	*NO YES					OFF ON			
SECTOR-SELECTION FEATURE	*NO YES						OFF ON		
DEMO MODE	*NO YES							OFF ON	
TEST MODE	*NO YES								OFF ON
SWITCH 4 (not used)					OFF				

*recommended settings

**For upright games, select ON for switch 2. Table games require OFF for switch 2.

†For games with a single coin selector or 2 selectors of the same value, S3 must be turned off. For games with selectors for 2 different coin values, S3 must be turned on.

CONNECTOR CN3

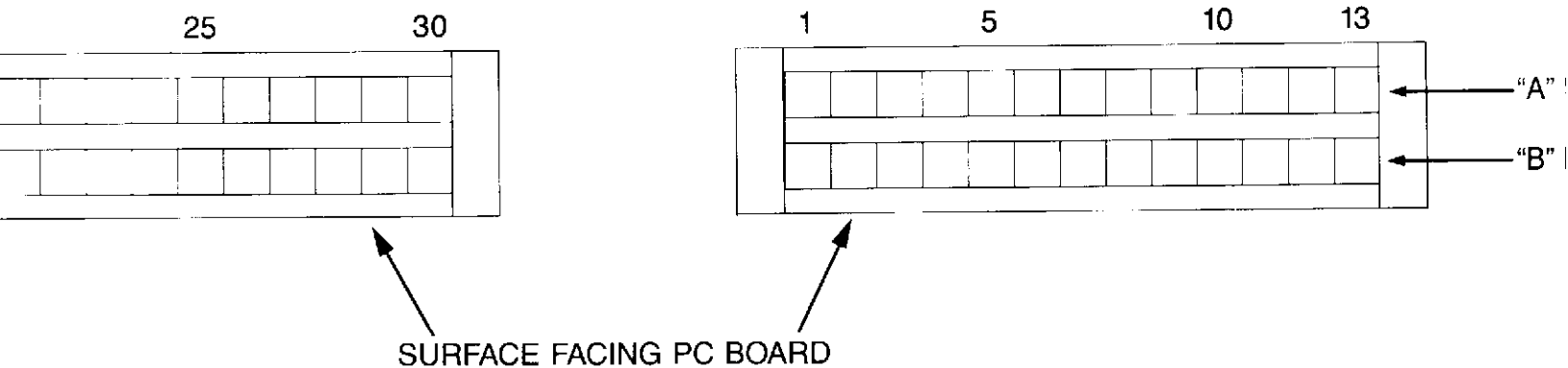

TIM
COU

Connector CN2

NO.	DESCRIPTION	PIN NO.	DESC.
HB1		16A	AB5
AB14		16B	+5V
HB2		17A	AB6
AB13		17B	+5V
HB4		18A	AB7
AB11		18B	+5V
HB8		19A	AB8
AB10		19B	+5V
HB16		20A	AB9
AB12		20B	+5V
HB32		21A	C8WT
AB15		21B	+5V
HB64		22A	C000RD
+5V		22B	+5V
HB128		23A	C000CS
+5V		23B	V256
HB256		24A	RESET
+5V		24B	D0WT
WAIT		25A	WRB
+5V		25B	H30
AB0		26A	1ORQB
+5V		26B	+CPR*
AB1		27A	RFSHB
+5V		27B	3DIM
AB2		28A	RDB
+5V		28B	NOT USED
AB3		29A	M1B
+5V		29B	NOT USED
AB4		30A	MREQB
+5V		30B	NOT USED

Connector CN3

PIN NO.	DESCRIPTION
1A	SP+
1B	SP+
2A	SP-
2B	SP-
3A	+12V
3B	+12V
4A	+5V
4B	GND
5A	+5V
5B	GND
6A	+5V
6B	GND
7A	NOT USED
7B	NOT USED
8A	NOT USED
8B	NOT USED
9A	D0
9B	D1
10A	D2
10B	D3
11A	D4
11B	D5
12A	D6
12B	D7
13A	NOT USED
13B	NOT USED

M52-A

M52-B

M52-E

ACTER PRIORITY*

M52-SOU

13

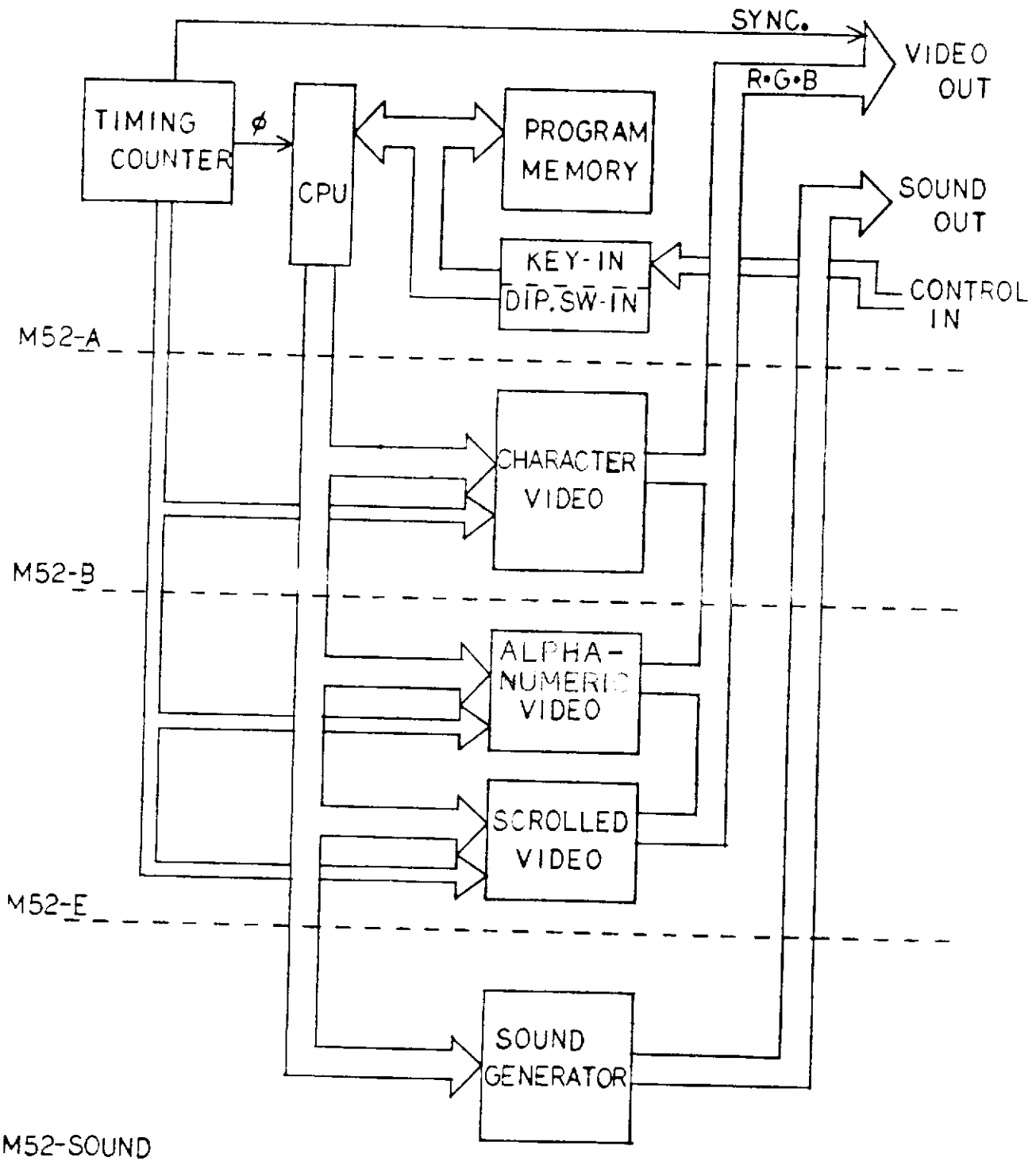
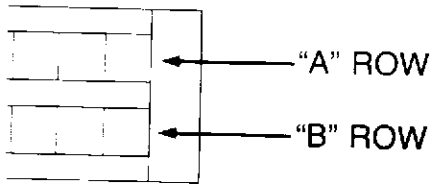

ION

ED
ED
ED
ED

ED
ED

Connector Identification and Block Diagram

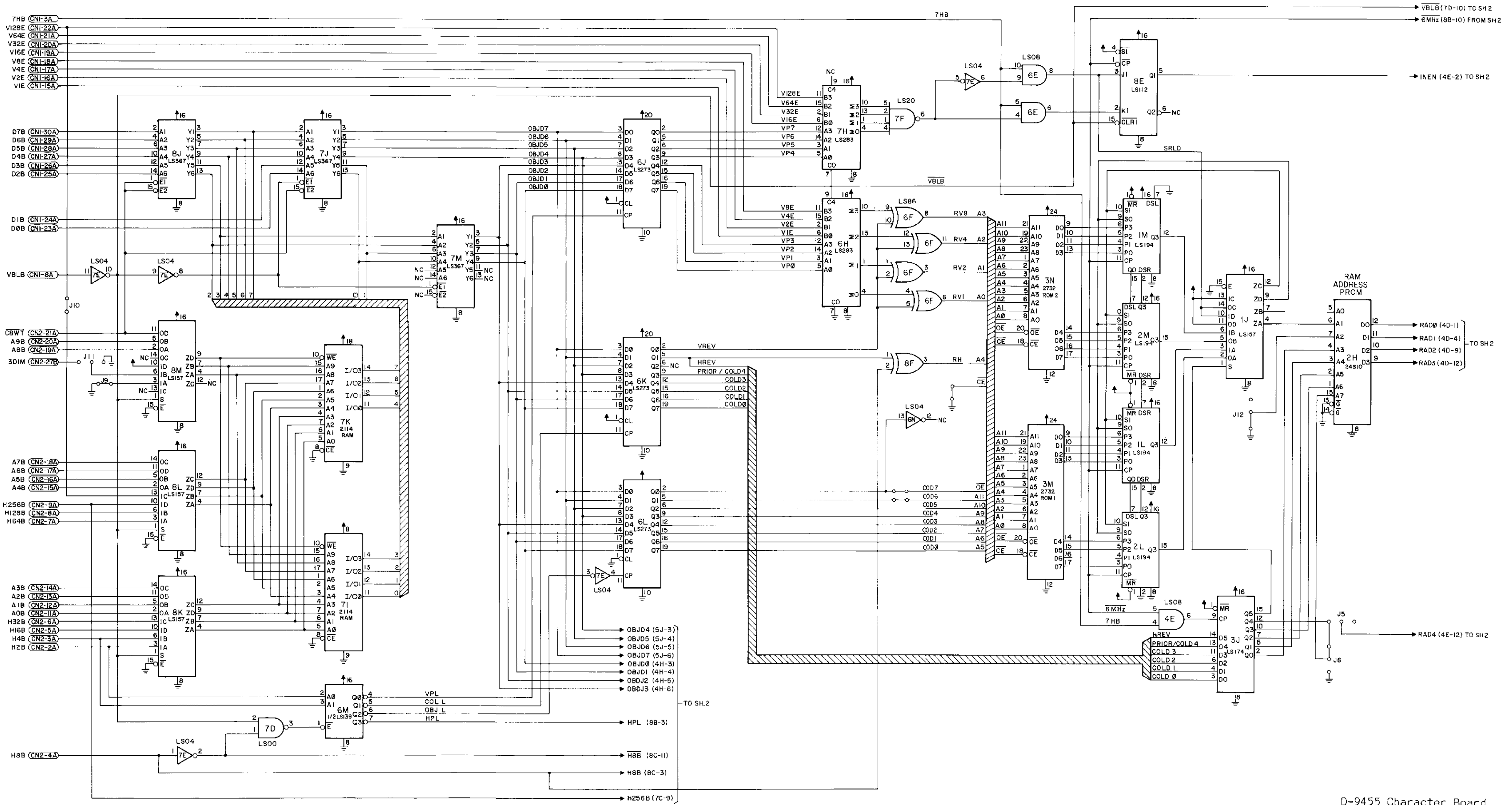

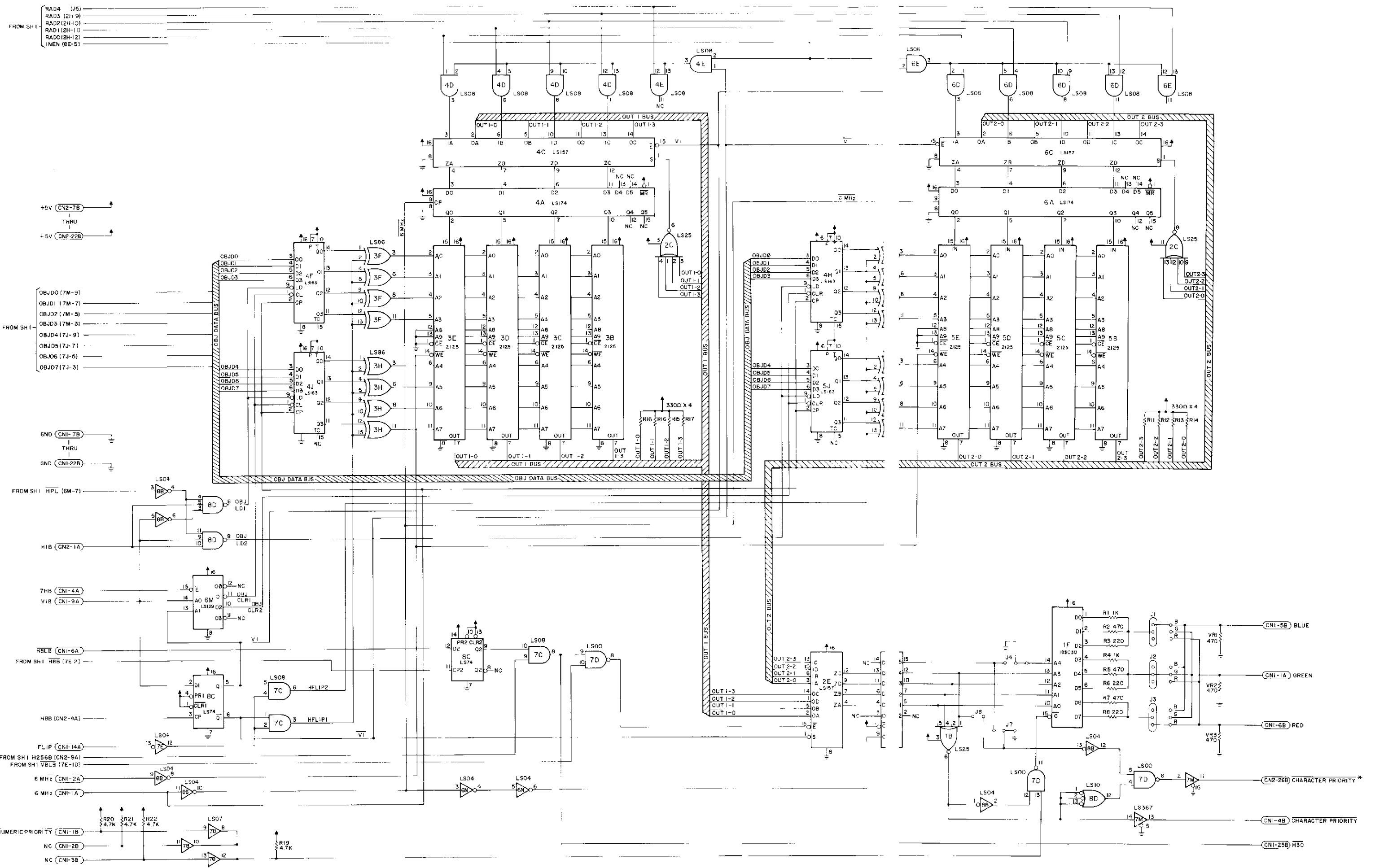

D-9455 Character Board
(M-52-B-C) Sheet 2 of 2

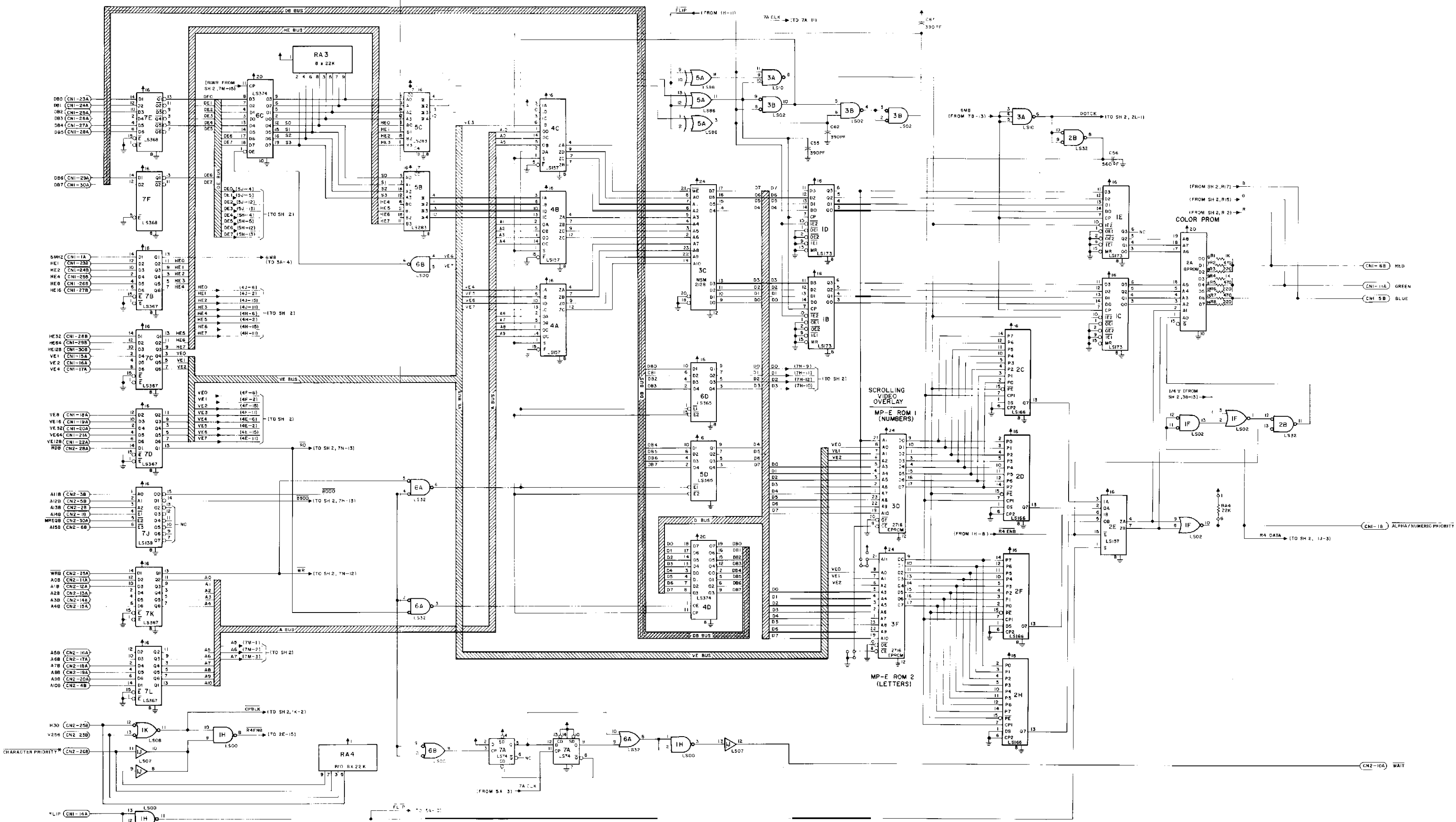

CN1-4B CHARACTER PRIORITY
(FROM SH1, 3A-6)

CN1-14A FLIP

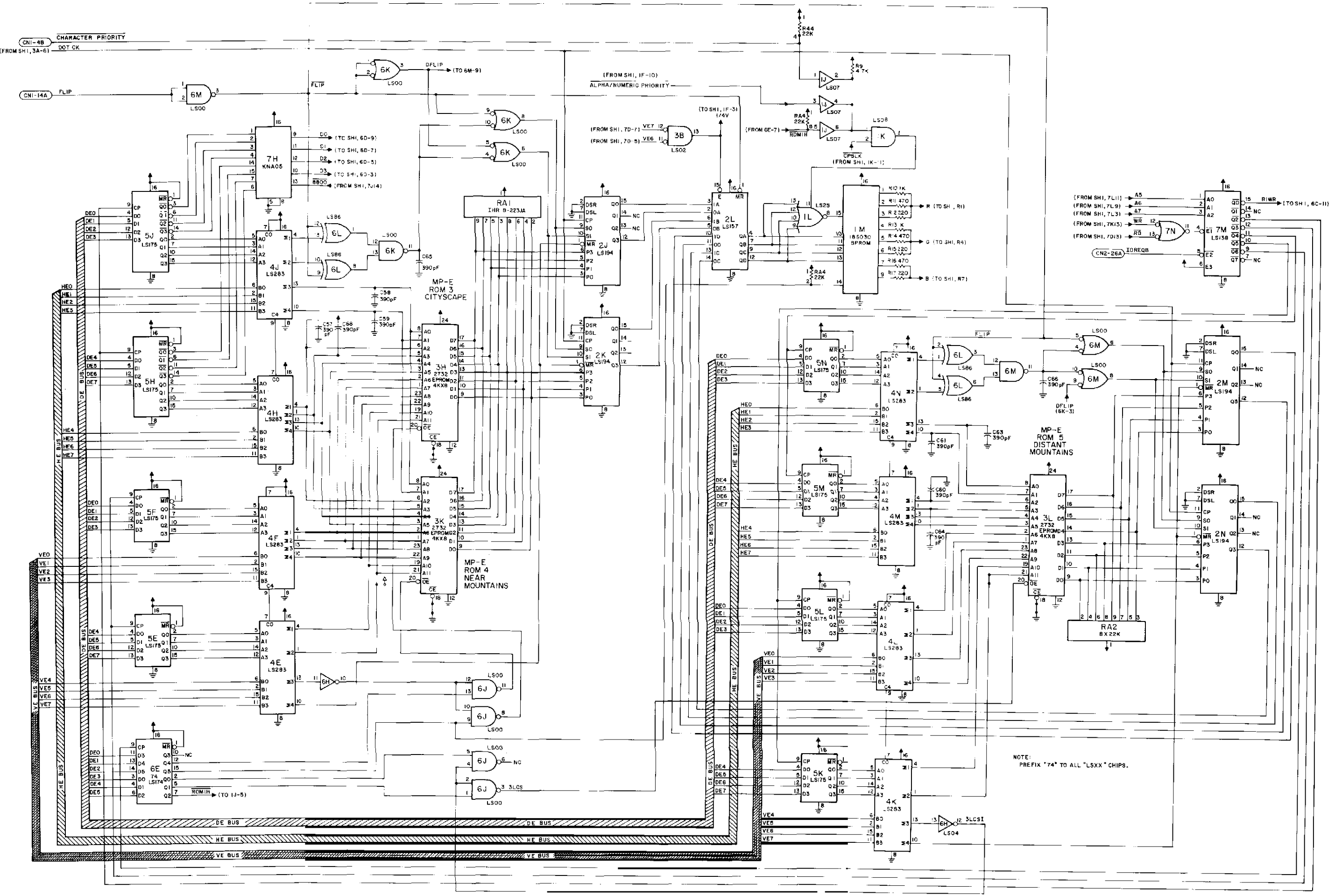

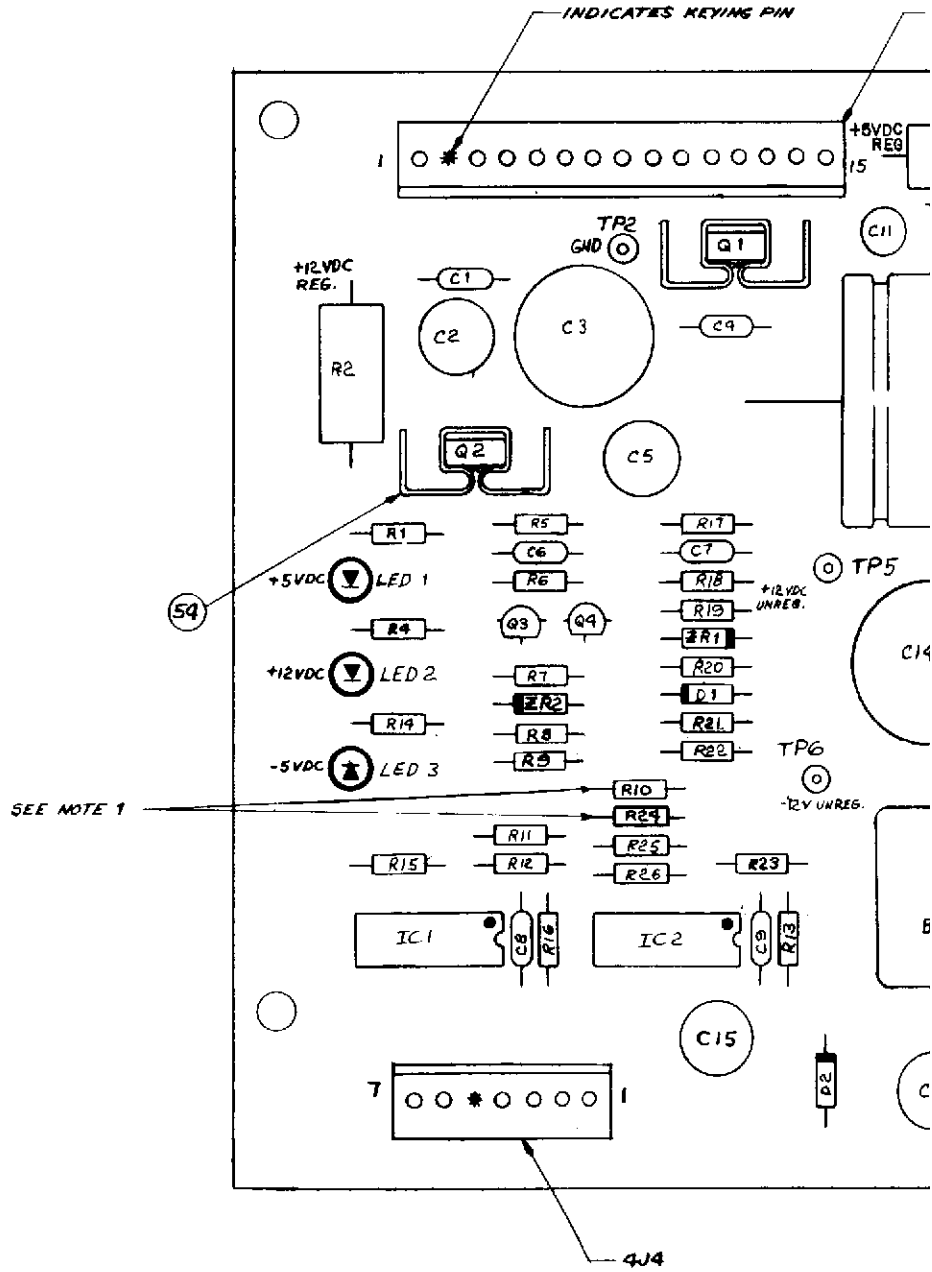

NOTES:

1. REMOVE R24 IF +5VDC IS GREATER THEN 5.25 VDC, REMOVE R10 IF +5VDC IS LESS THAN 4.75 VDC.
2. BR1 MUST BE MOUNTED 1/8" ABOVE SURFACE OF BOARD.
3. FOR SCHEMATIC REFER TO 16-8811.

55	5010-02682-00
56	5010-09324-00
ITEM NO.	PART NO.

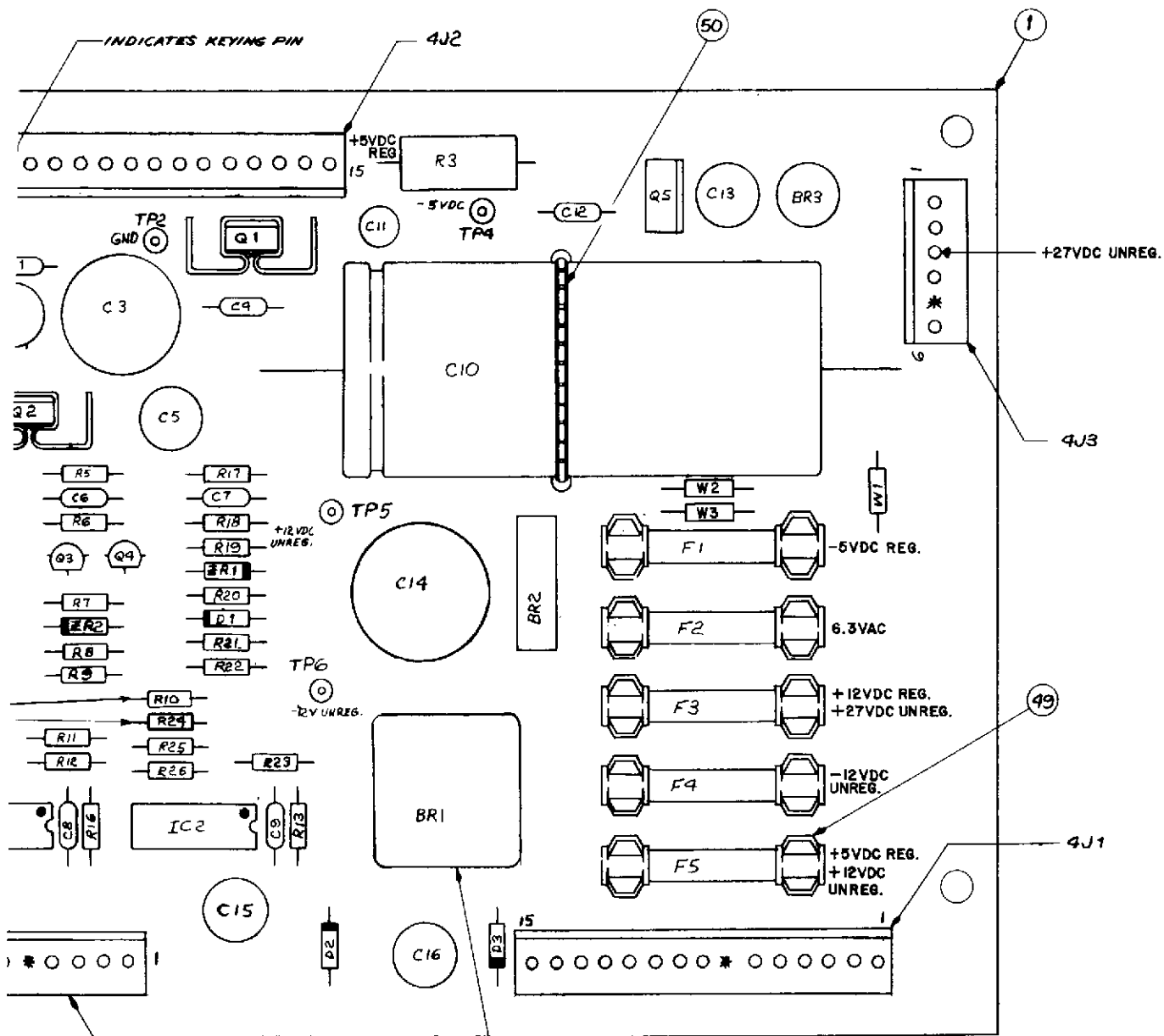

F +5VDC IS GREATER THEN 5.25 VDC,
 F +5VDC IS LESS THAN 4.75 VDC.
 MOUNTED 1/8" ABOVE SURFACE OF
 REFER TO 16-8811.

SEE NOTE 2

45	5731-09432-00	F4 & F5	FUSE, TA.S.B.	
46	5731-06314-00	F3	FUSE, 4A, S.B., 250V	
47	5731-06569-00	F1	FUSE, 1A, S.B. 250V	
48	5731-09651-00	F2	FUSE, 5A, S.B. 250V	
49	5732-09178-00		FUSEHOLDER,	
50	03-7520		TIE WRAP	
51	5731-09074-00	4J1 & 4J2	HEADER, 15 PIN 09-65-1051	
52	5731-09038-00	4J3	HEADER, 6 PIN 09-65-1061	
53	5731-09497-00	4J4	HEADER, 7 PIN 09-65-1071	
54	5705-09663-00		HEAT SINK	
	5705-09688-00		HEAT SINK	
55	5010-09682-00	R10	RESISTOR, C.F. 51K ± 5% 1/4W	
56	5010-09324-00	R24	RESISTOR, C.F. 27K ± 5% 1/4W	
ITEM NO.	PART NO.	PART DESIGNATION	DESCRIPTION	REQ'D NO

BILL OF MATERIAL

ITEM NO.	PART NO.	PART DESIGNATION	DESCRIPTION	REQ'D NO.
1	5773-09679-00		BARE P.C. BOARD	1
2	5010-09085-00	R23	RESISTOR, 1.5K 5%, 1/4W	1
3	5010-09441-00	R13, R15	RESISTOR, 2.7K 2%, 1/4W	2
4	5010-09508-00	R21	RESISTOR, 270Ω 2%, 1/4W	1
5	5010-09428-00	R20	RESISTOR, 1.5K 2%, 1/4W	1
6	5010-09509-00	R16	RESISTOR, 1.1K 2%, 1/4W	1
7	5010-09510-00	R7	RESISTOR, 12K 2%, 1/4W	1
8	5010-09314-00	R4	RESISTOR, 1.2K 5%, 1/4W	1
9	5010-09416-00	R1, R14	RESISTOR, 470Ω 5%, 1/4W	2
10	5013-09542-00	R11	RESISTOR, 7.32K 1%, 1/4W	1
11	5013-09427-00	R12	RESISTOR, 9.99K 1%, 1/4W	1
12	5013-09426-00	R25	RESISTOR, 2.15K 1%, 1/4W	1
13	5012-09429-00	R3	RESISTOR, .12Ω 5%, 5W	1
14	5012-09512-00	R2	RESISTOR, .27Ω 5%, 5W	1
15				
16	5013-09665-00	R26	RESISTOR, 5.11K 1%, 1/4W	1
17	5010-09434-00	R6, R18	RESISTOR, C.R. 22Ω ±5%, 1/4W	2
18	5010-09036-00	R5, R9, R17, R22	RESISTOR, C.F. 100Ω ±5%, 1/4W	4
19	5010-09039-00	R8, R19	RESISTOR, C.F. 10Ω ±5%, 1/4W	2
20	5010-09534-00	W1	RESISTOR, 0Ω	1
21	5043-08986-00	C6, C7	CAPACITOR, 0.1μF CERAMIC +80% -20% 50V	2
22	5040-09421-00	C2, C16	CAPACITOR, 100MFD, 25V RADIAL +50% -10%	2
23	5040-09422-00	C15	CAPACITOR, 47MFD, 50V RADIAL +50% -10%	1
24	5040-09420-00	C3	CAPACITOR, 1000MFD, 25V RADIAL +75% -10%	1
25	5040-09419-00	C10	CAPACITOR, 18,000MFD 20V AXIAL +75% -10%	1
26	5040-09423-00	C5	CAPACITOR, 330MFD 10V RADIAL +50% -10%	1
27	5040-09504-00	C14	CAPACITOR 4700MFD 35V RADIAL +50% -10%	1
28	5043-09446-00	C1, C4 & C12	CAPACITOR .1MFD, 50V AXIAL 25V -20 +80%	3
29	5043-08065-00	C9	CAPACITOR 470PFD 50V AXIAL XTR ±10%	1
30	5043-09492-00	C8	CAPACITOR 100PFD 50V AXIAL 52L ±5%	1
31	5040-09506-00	C13	CAPACITOR 220MFD 16V RADIAL +50% -10%	1
32	5040-09493-00	C11	CAPACITOR 22MFD 10V RADIAL +50% -10%	1
33	5070-06258-00	D1, D2 & D3	DIODE, 1N4001	3
34	5075-09406-00	ZR1	ZENER, 1N5234 ±5% (6.2V)	1
35	5075-09662-00	ZR2	ZENER 1N5244 ±5% (14V)	1
36	5190-09430-00	Q3, Q4	TRANSISTOR, MPS A55	2
37	5130-09661-00	Q1, Q2	SCR 8 AMP, 100V	2
38	5250-09515-00	Q5	VOLTAGE REGULATOR, 7905	1
39	5440-09424-00	IC1, IC2	VOLTAGE REGULATOR, 723	2
40	5700-09400-00	BR1	BRIDGE RECTIFIER, 35 AMP, 200V	1
41	5100-09513-00	BR2	BRIDGE RECTIFIER, 4.0A, 50V	1
42	5100-09514-00	BR3	BRIDGE RECTIFIER, 1.0A, 50V	1
43	5671-09018-00	LED1, LED2, LED3	LED, RED	3
44	5824-09298-00	TP1 - TP6	TERMINAL # 1502-1 (TEST POINT)	4

(A)

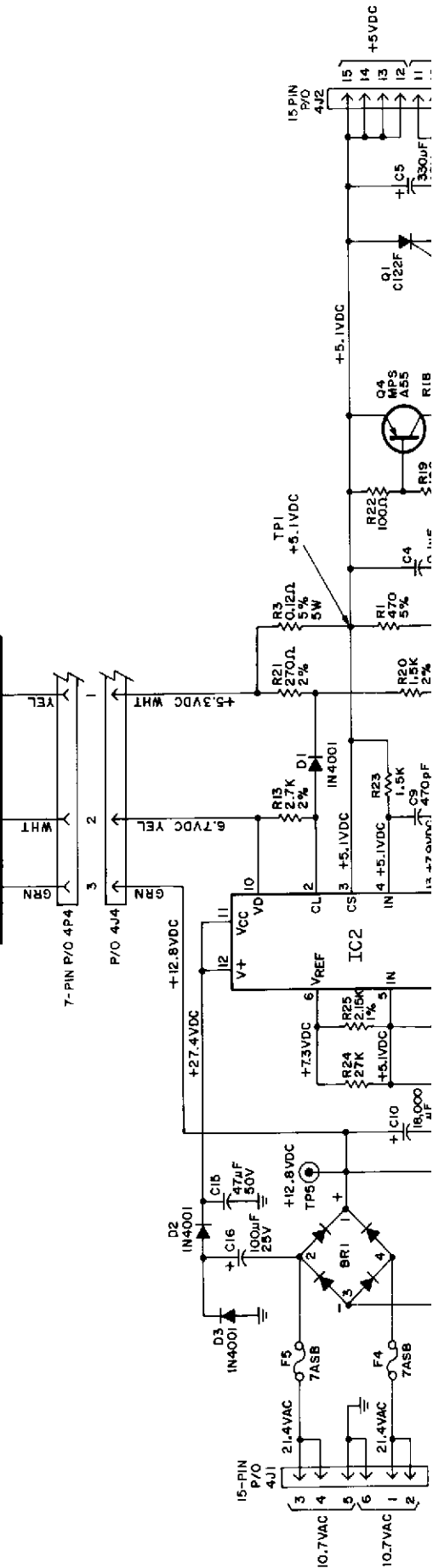
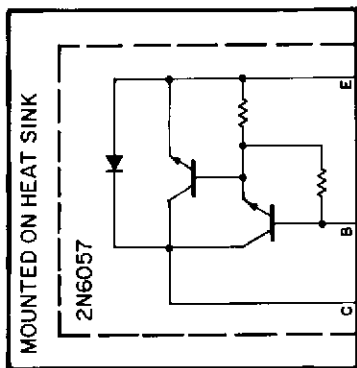

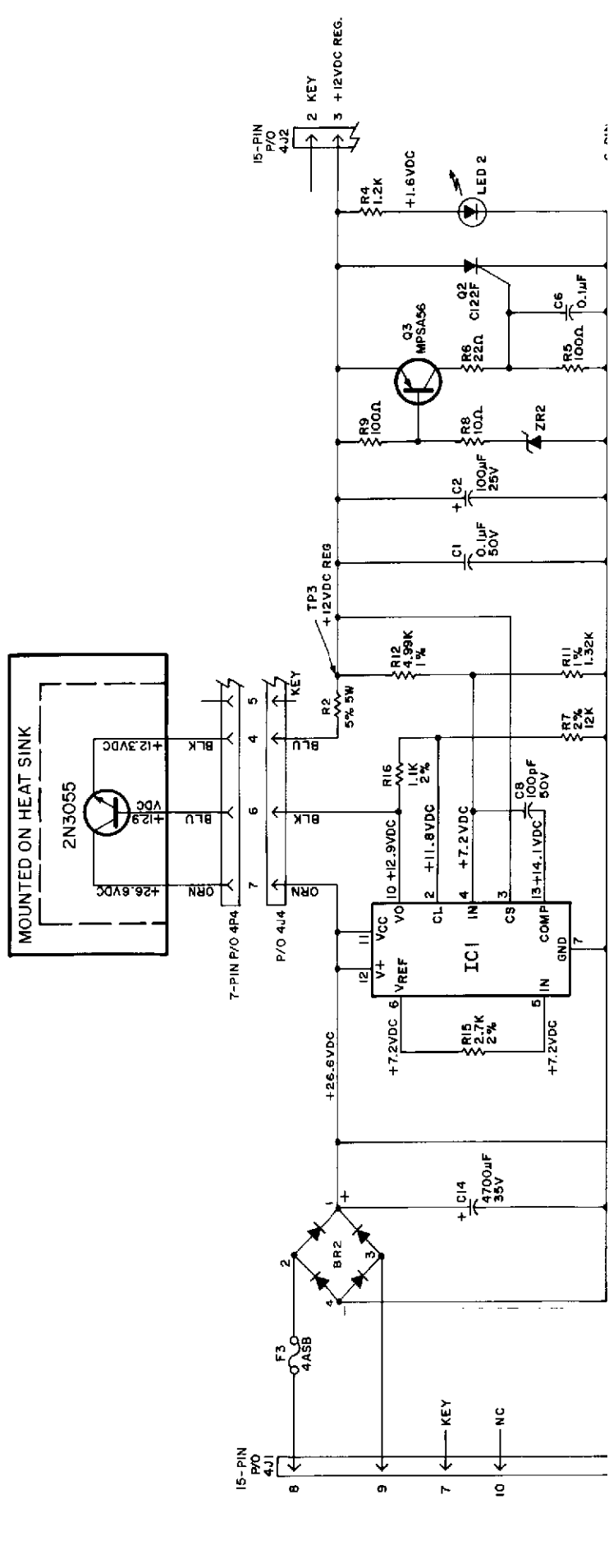
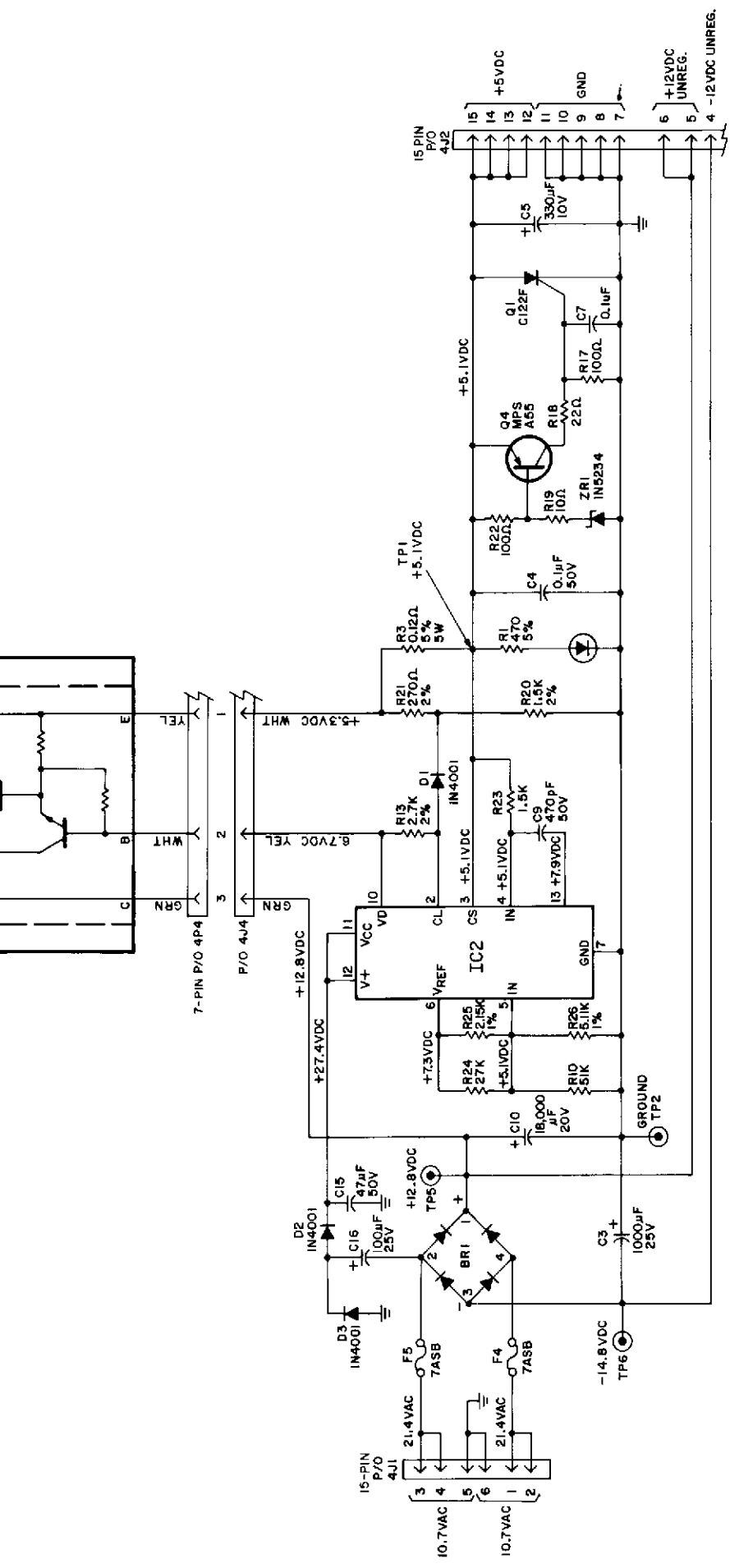

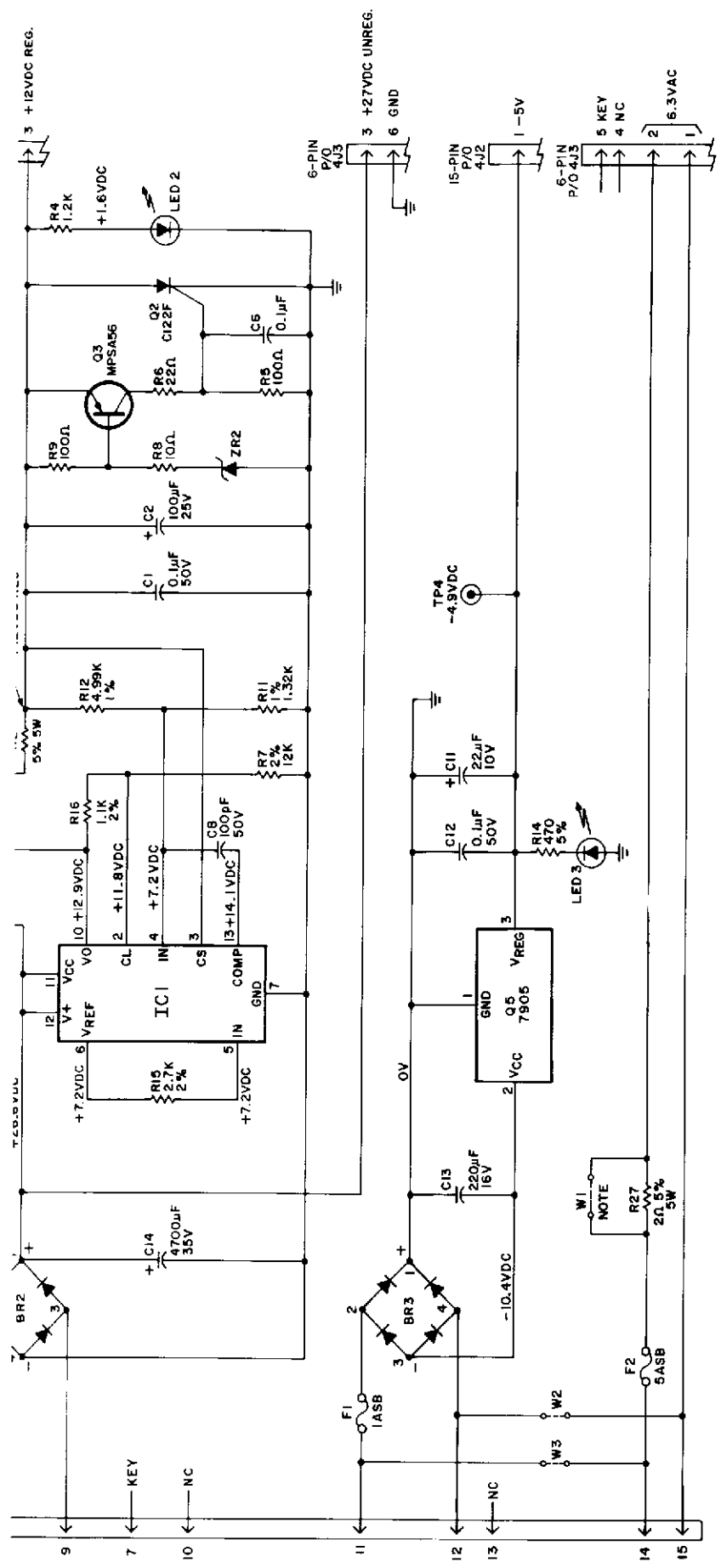

D-8784-3007 Power Supply Board Schematic Diagram

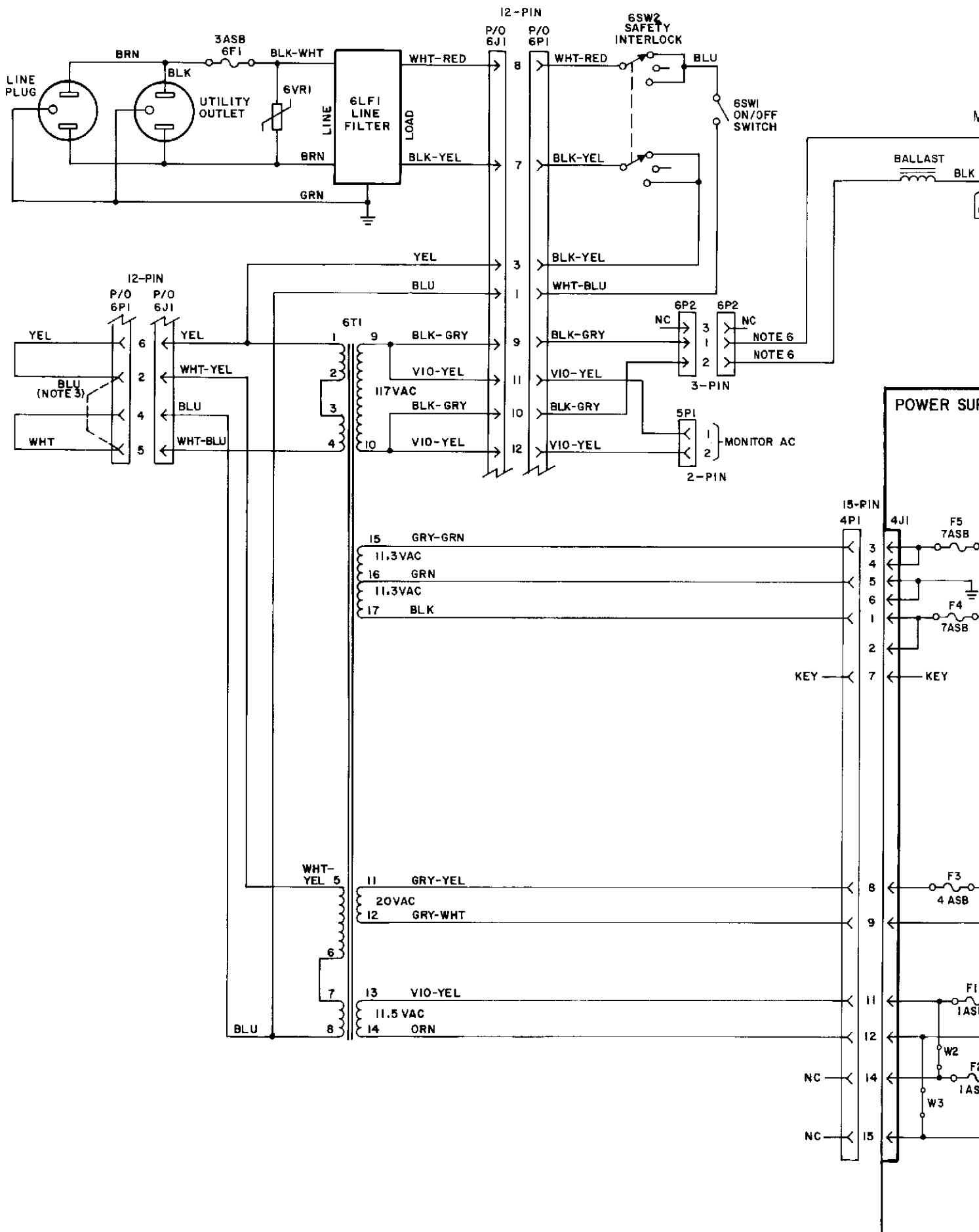

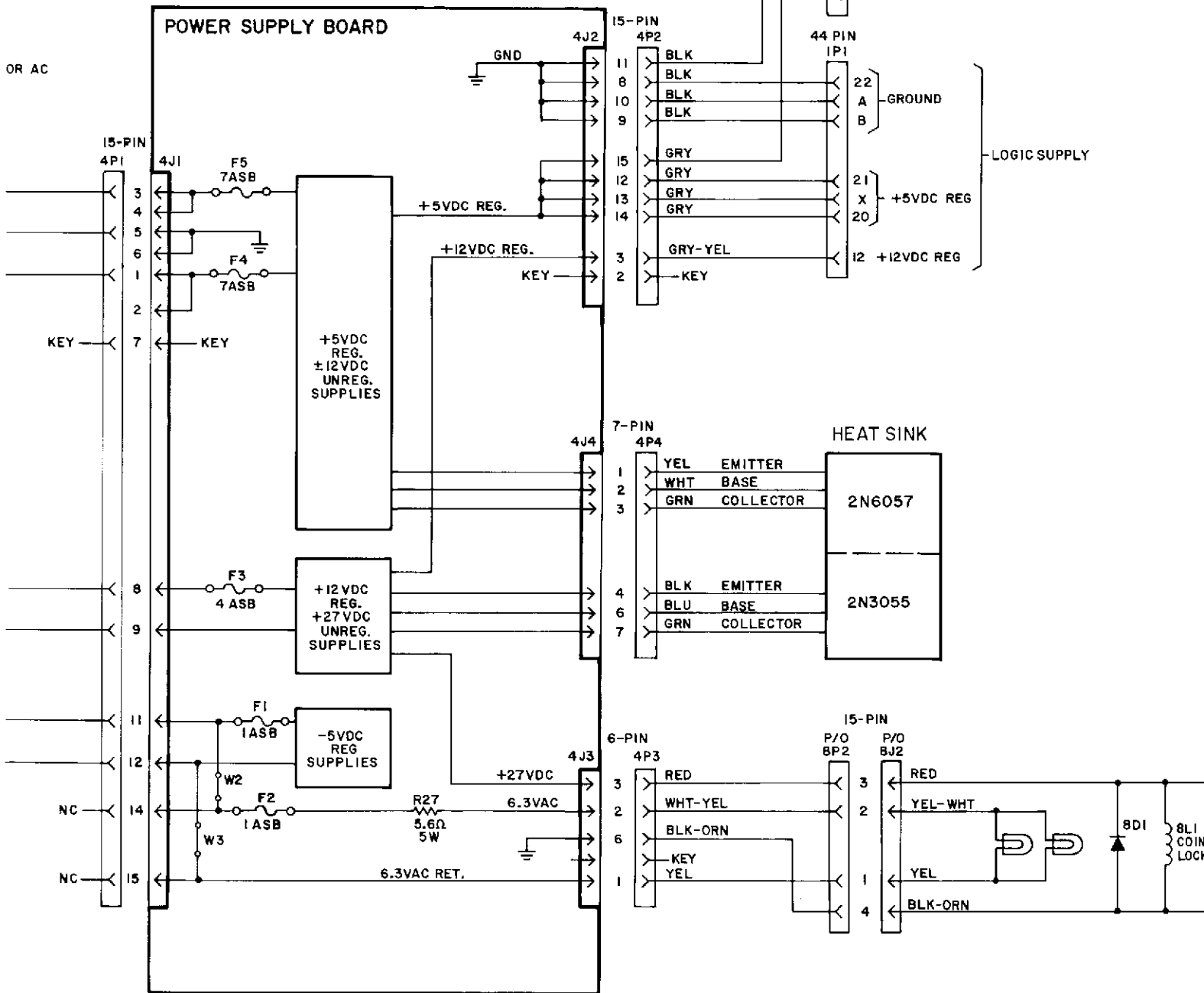
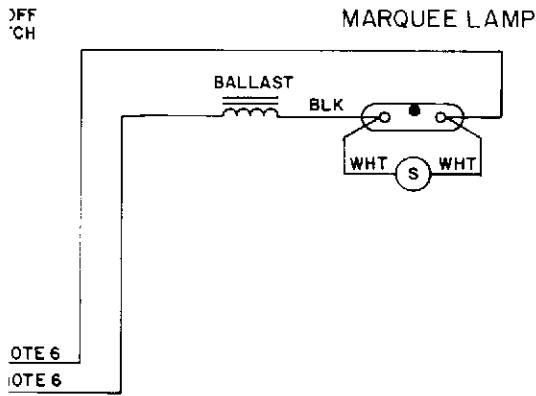

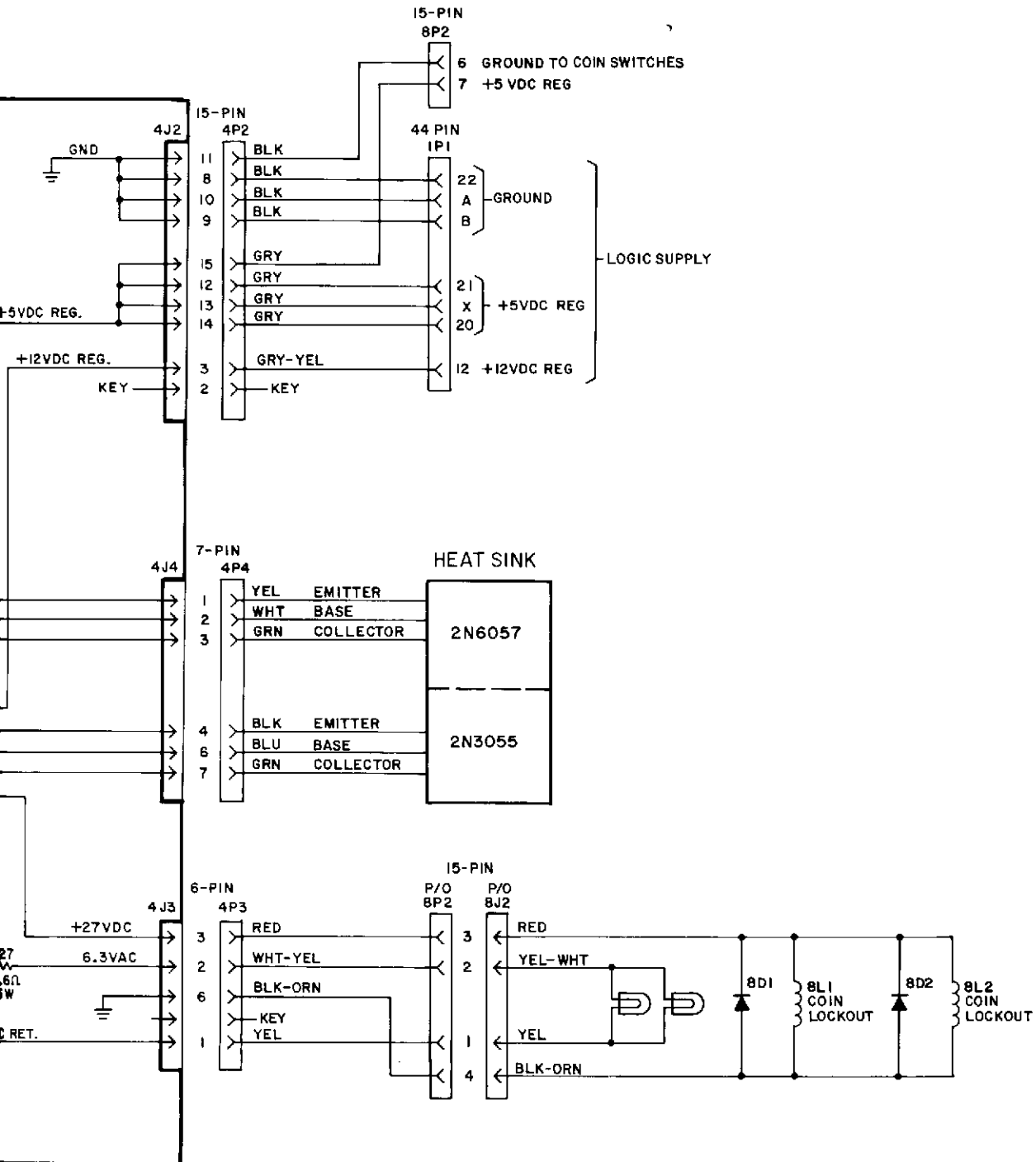

Power Wiring Diagram

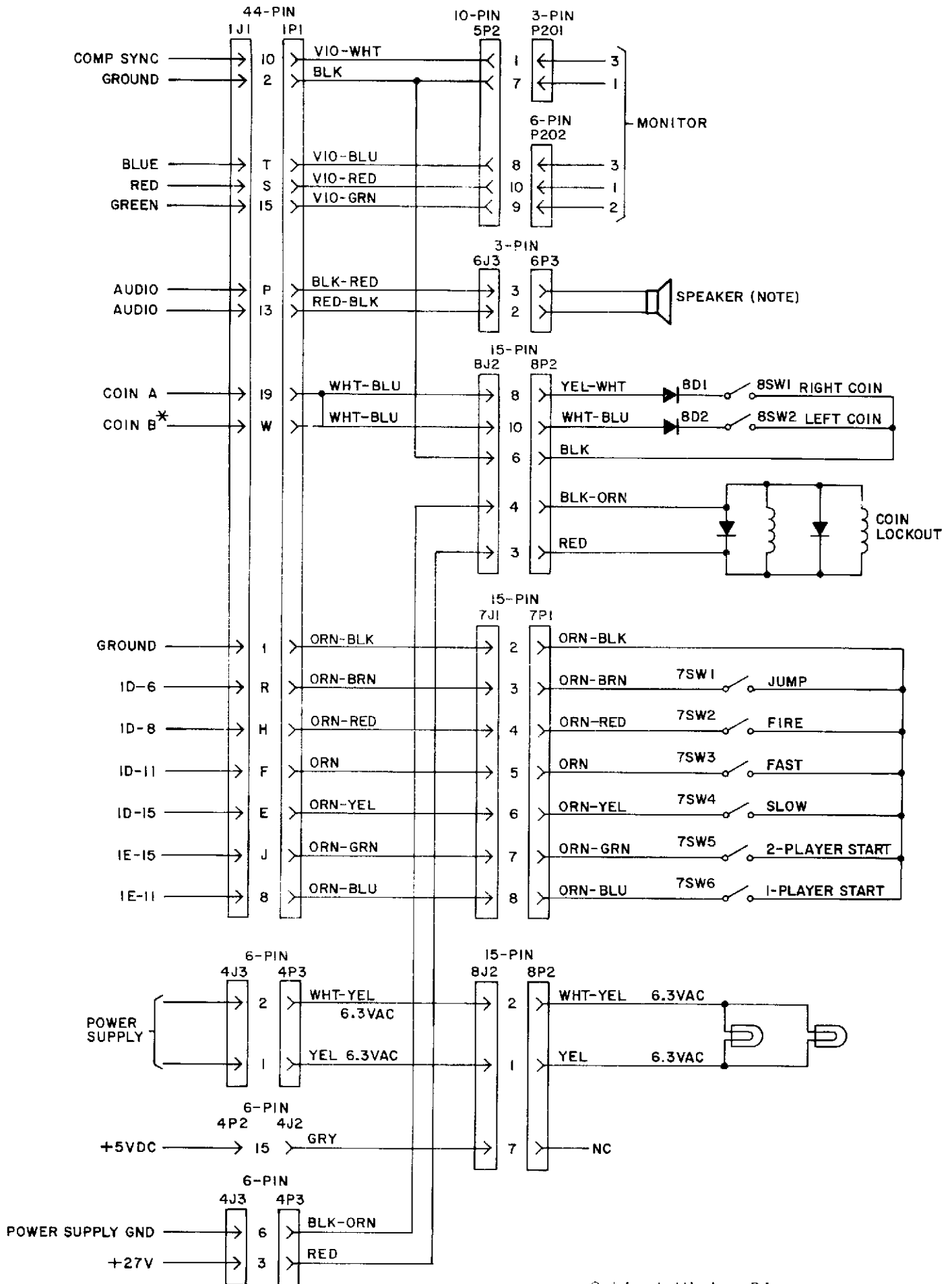

Cabinet Wiring Diagram